



38MT+™

Heavy Duty Gear Reduction Starter



Features & Benefits

- **Available* with Integrated Over Crank Protection (IOCP)**, a built-in circuit breaker, protects the starter from thermal damage, automatically resetting at a safe operating temperature while eliminating the need for a wiring harness.
- **38MT+ features an Integral Magnetic Switch (IMS)**. IMS reduces voltage drop and ensures the solenoid receives the maximum available voltage in any starting condition.
- **Electrical soft-start** consistently and accurately engages the pinion with the ring gear providing increased reliability.
- **Warranty:****
Non-OCP model:
1 year / unlimited miles
Integrated OCP model:
3 years / unlimited miles

* Part Number 8201084

** Applicable to U.S. and Canada only

38MT+ designed to fit MX 11 and 13 liter engines

SPECIFICATIONS

Engine Size	up to 13 liter
Rotation	Clockwise
Mounting	SAE #3
Pinion Data	12 Tooth, Mod 3-metric
Output	4.3kW peak at 12V
Weight	12.9 kg/28.44 lbs
Diameter	100 mm/3.94 inches
Heavy Duty Drive	Electrical Soft-Start, Engagement System, Overrunning Clutch

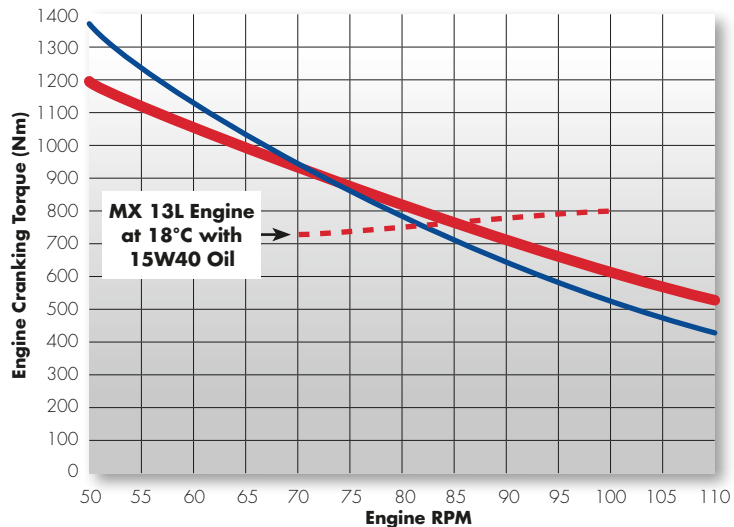

Cranks 4% faster than the competition

— 38MT+ @ 2mOhm
— Melco @ 2mOhm



* Integrated Over-Crank Protection (IOCP)

4% lighter than the competition

38MT+™

Heavy Duty Gear Reduction Starter

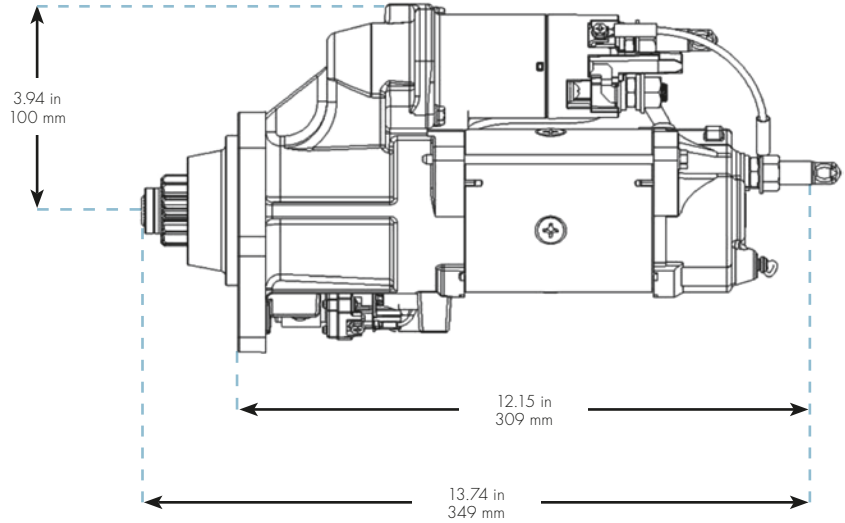

OEM	Engine	Non-OCP 38MT+	Integrated OCP 38MT+	Teeth/Pinion/Pitch	Melco
PACCAR	MX 11/13	8200977	8201084	12 Tooth, Mod 3 Metric	D61-1003-001 D61-6002-011 M009T72578 M9T72578 PC2578 1847916

COMPETITIVE COMPARISON			
Starter Model	OCP	Faster Cranking	Weight
Delco Remy 38MT+	Optional	82 Engine RPM	28.44 lbs/12.9kg
Melco	No	79 Engine RPM	29.32lbs/13.3kg

Tech Support 800-372-3555

If you need assistance with part number identification or electrical system troubleshooting, we're here to help.



**Part numbers fast
at delcoremy.com**



© BorgWarner Inc.
600 Corporation Drive
Pendleton, IN 46064 USA
For Customer Service or Technical
Assistance call 1-800-372-3555

delcoremy.com

Delco Remy is a registered trademark of General Motors Corporation
licensed to Remy LLC, Pendleton, IN | C11142 | 7-16